

DIATEX

Composite process materials

Composite division

Vacuum moulding

Vacuum infusion and infujection

Reusable membranes

RTM & RTM Light

Vacuum equipment



www.diatex.com

 EN 9100
ISO9001
Oeko-Tex®

DIATEX

Composite process materials



www.diatex.com

 EN 9100
ISO9001
Oeko-Tex®

Technology, skill and quality since 1986

Based near Lyon, France, DIATEX is specialized in technical fabrics and supplies all types of bagging materials used in vacuum moulding, vacuum infusion, RTM and RTM Light processes in composite-parts production. DIATEX set up its production site in the Rhône-Alpes region, at the heart of the textile industry, to facilitate close quality control from start to finish. Thus DIATEX ensures appropriate standards at each and every stage of the production of its technical peel-ply fabrics.

Synergy of subsidiaries : at the core of development

DIATEX works in close collaboration with its technical textile and textile finishing subsidiaries to design new products in aim of facilitating the work of composite material transformers. As requested by its customers, DIATEX and its partners draw up specifications which define and optimize the technical features of their products.

Concerned about environmental protection issues and the health of product users, DIATEX is moving increasingly into the framework known as "Eco Design" to meet customer requirements. The aim is to manufacture a range of bagging materials which respect REACH standards and Oeko Tex Certification as ecologically harmless for humans.

Technical support based on innovating processes

DIATEX's success is founded on a thorough knowledge of its customers' needs and an innovative approach towards the development and manufacture of products that make their jobs easier. As a result, productivity is increased and storage costs are reduced for customers.

Dedicated to quality is more than a commitment

As formal evidence of its commitment to professional quality management, DIATEX has successfully completed its follow-up audit for the updated ISO 9001:2008, EN9100 and V2009 certifications, placing it among the leading certified suppliers to the aerospace industry.



Our partners



A Chem-Trend Brand



Contents

1. Vacuum moulding

Bagging materials	3
- VACUOPLEX® and VACUOLEASE® - VACUOPLEX® MP ...	4
- VACUOLEASE.....	5
- Peel ply	5
- Bagging films	6
- Perforated release films.....	6
- Bleeders and breathers	7
- Glass tapes.....	7
- PTFE and silicone release interfaces.....	7
- Thermoshrinkable fabrics and films.....	8
- Sealant tapes	8
- Flash Tapes	8
Accessories	8

2. Vacuum infusion & Infujection

Bagging materials	10
- INFUPLEX	10
- Bagging films	11
- Perforated films	11
- Net bleeders.....	11
- Peel ply	12
- PTFE and silicone release interfaces.....	12
- Sealant tapes	13
- Adhesive spray	13
- Spiralnet.....	14
- Spiral MP.....	14
- Diadrain MP.....	14
- Adhesive glass screen tape	15
Accessories	15

3. Reusable membranes

Reusable membranes	16
- Customized membranes	17
- Spraying equipments.....	17
- Silicone ancillaries.....	17

4. RTM & RTM light

- V400 Injection Valve	19
- In mould air ejector	19
- Overlay.....	19
Accessories	20

5. Vacuum equipment

Vacuum pumps	22
Vacuum plants Minivac and Indusvac	23
Vacuum plant Compositvac	23
Vacuum regulator and vacuumeters.....	24
Leak detector.....	24
IMPS Control of vacuum level.....	24
Infrared thermometer gun	24

1. Vacuum moulding

DIATEX has designed a specific range of bagging materials for preregs and hand lay-up composite materials with vacuum polymerization. The success of DIATEX is based on the manufacture of innovating products, such as VACUOPEEL®, whose purpose is to facilitate the application of environmental products by users during drape moulding operations. DIATEX also offers all standard environmental products as well as the equipment which is used in this manufacture process in compliance with our quality systems (EN 9100 v 2009 - ISO 9001 v 2008 - Bureau Veritas).

Bagging materials VACUOPLEX® - VACUOPEEL® - VACUOLEASE

Save money, optimise your production !

Traditional diagram of Vacuum moulding

DIATEX brings technical support in order to optimize vacuum moulding process with high performance bagging materials. Solve your different problems with VACUOPLEX®, VACUOPEEL® and VACUOLEASE range.

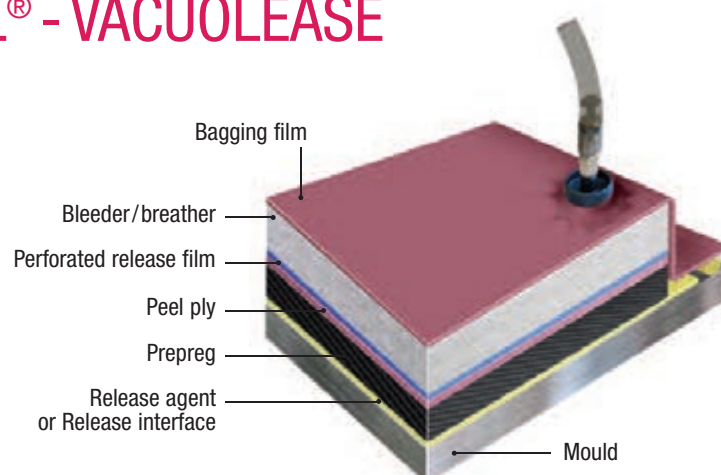

Multilayer system range developed by DIATEX

Product	Peel ply	Perforated film	Perforated release film	Microporous film	Bleeder/Breather
VACUOPLEX MP®	X			X	X
VACUOPLEX®	X	X			X
VACUOPEEL®	X		X		X
VACUOLEASE			X		X
MP FABRICS	X			X	

More details  www.diatex.com



VACUOPLEX® and VACUOPEEL®

VACUOPLEX® and VACUOPEEL® are multilayer systems developed by DIATEX in order to improve the efficiency of the vacuum moulding process (Prepreg and wet lay-up). They combine 3 consumables in only one product: peel ply + perforated release film + breather/bleeder.

Use on small or big parts in direct contact with the resin. VACUOPLEX® and VACUOPEEL® can be prepared with hot knives or scissors. During the curing processes, they will degas and remove the excess of resin more effectively than the traditional method. VACUOPLEX® has to be removed in one time. VACUOPEEL® can be peel off in two times, therefore to leave the peel ply on the laminate and remove it later. Different combinations of VACUOPLEX® and VACUOPEEL® are available.

Optimized system by DIATEX

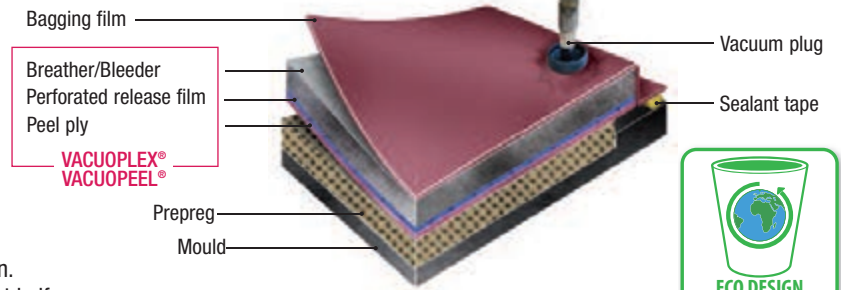

VACUOPLEX® 1 step

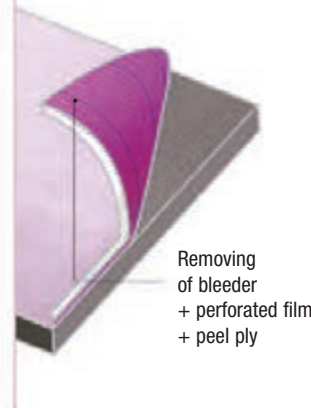

VACUOPEEL® 2 steps



VACUOPLEX® MP

VACUOPLEX® MP is a microporous multilayer system used in manufacturing processes for vacuum moulding of composite materials with techniques such as prepreg, wet lay-up. It is a VACUOPLEX® evolution, it gives many benefits to the producers: save time and improve the composites quality. Under vacuum the resin can't pass through the non-woven bleeder, so vacuum acts uniformly on the entire area during all the curing process, and the resin can't stop as it is blocked under the microporous film.

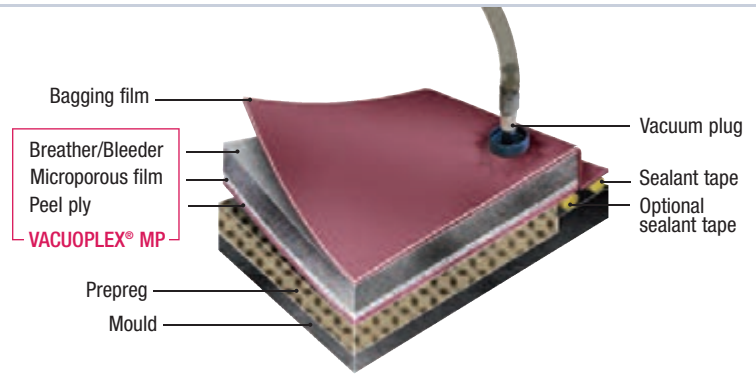

Product	Peel ply	Bleeders / Breather	Perforated release film	Dimensions	Application	Use with resin
VACUOPLEX MP	PA100 ST Pink polyamide without stripes	PES150 150 gr/m ²	P	1.50 x 50 m	Prepreg	E, VE
VACUOPLEX	PA85 Polyamide	PES340 340 gr/m ²	P	1.50 x 50 m	Bonding	E, VE
VACUOPEEL	PA90 Pink polyamide	PES340 340 gr/m ²	P	1.50 x 50 m	Carbon	E, VE
VACUOPEEL	PA80 Polyamide	PES200 200 gr/m ²	P	1.50 x 50 m	Economic standard	E, VE
VACUOPEEL	PA64 Polyamide	PES200 200 gr/m ²	P	1.50 x 50 m	Thin surface	E, VE
VACUOPEEL	PES85 Polyester	PES340 340 gr/m ²	P	1.50 x 50 m	Phenolic resin	E, PH, EL
VACUOLEASE	ETFE P3	PES150 150 gr/m ²	ETFE P3	1.50 x 50 m	All application MV	E, PH, EL
VACUOLEASE	PP40 P3	PES340 340 gr/m ²	PP40 P3	1.50 x 50 m	All application MV <160°	E, VE, PH

E : epoxy VE : vinyl ester EL : elastomer PH : phenolic

More details www.diatex.com



VACUOLEASE

VACUOLEASE is the combination of two consumables developed for the vacuum moulding technology. This multilayer system facilitates the implementation of the consumable. The perforated film and the bleeder are laminated in only one single product.

Use VACUOLEASE on small or big parts in direct contact with the resin (perforated film side in contact with the resin). You can prepare VACUOLEASE with hot knife or scissors.

During the curing process, VACUOLEASE will degas and remove the excess of resin more effectively than the traditional method. After the curing process, remove VACUOLEASE in one piece.



Peel ply

Complete range of peel plies : from 64 to 185 gr/m², dyed, white or undyed with stripes, polyamide or polyester, bands or full Width. Peel ply "PA85" is the standard quality, taffetas weave, 85 gr/m², white with stripes. Peel plies are used to impart a textured surface to the moulded component to improve adhesion in secondary bonding or painting. We are able to manufacture your own peel ply with specific characteristics. All our peel plies are treated in order to remove all pollutant products (like silicones for example) which could contaminate the laminate.

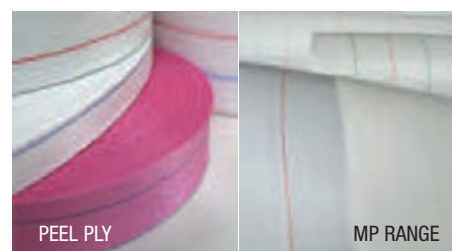

Peel ply MP (Microporous)

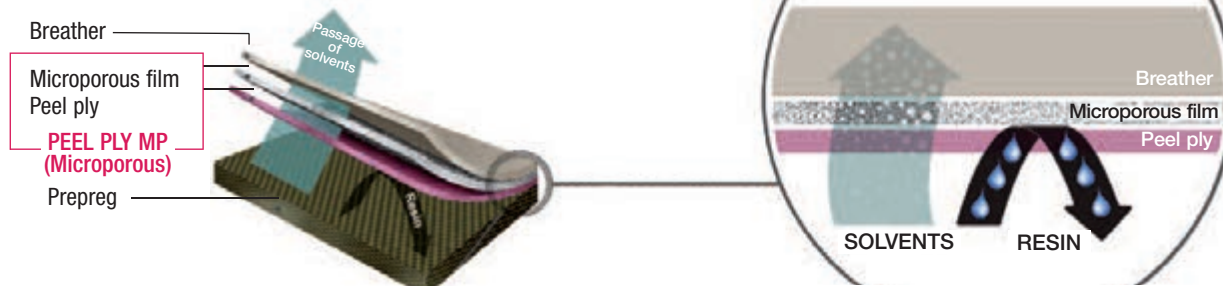

Peel ply MP is a microporous multilayer system used in manufacturing processes for vacuum moulding of composite materials with techniques such as : prepreg, wet lay-up and thermoplastic. The perforated film is now replaced by a microporous film full of tiny pores. Under vacuum the liquid (resin), can't pass through the film, excepted the gases.

Product	Max. temp.	Weight	Width	Length	Type	Colour	Characteristics/ Use
PA64	190°C	64 gr/m ²	1.57 m	100 m	Polyamide	White / Red stripes	Thin surface/Elastomere
PA80	185°C	80 gr/m ²	1.56 m	100 m	Polyamide	White / Red and blue stripes	Economic
PA80 MP	120°C	117 gr/m ²	1.50 m	50 m	Polyamide + MP film	White / Red and blue stripes	Prepregs low temperature
PA80 AD	185°C	80 gr/m ²	1.56 m	100 m	Polyamide + Adhesive	White / Red and blue stripes	Adhesive Peel ply
PA80 Fluo	185°C	83 gr/m ²	1.63 m	100 m	Polyamide	Yellow / Red and blue stripes	Carbon
PA85	185°C	85 gr/m ²	1.60 m	100/500 m	Polyamide	White / Blue stripes	Standard
PA90	185°C	90 gr/m ²	1.56 m	100/500 m	Polyamide	Pink / Blue stripes	Carbon
PA91	200°C	91 gr/m ²	1.60 m	100 m	Polyamide	White / Red stripes	Hand lay up / Infusion
PA95	185°C	104 gr/m ²	1.56 m	100/500 m	Polyamide	White / Blue stripes	Bonding
PA95 ST	185°C	104 gr/m ²	1.56 m	100/500 m	Polyamide	White	Bonding
PA100	185°C	107 gr/m ²	1.56 m	100/500 m	Polyamide	Pink / Blue stripes	Carbon
PA100 ST	185°C	107 gr/m ²	1.56 m	100/500 m	Polyamide	Pink	Carbon
PA100 ST MP	180°C	144 gr/m ²	1.50 m	50 m	Polyamide + MP film	Pink	Carbon
PA105	185°C	105 gr/m ²	1.60 m	100 m	Polyamide	White / Blue stripes	Developed shape
PES85	210°C	85 gr/m ²	1.64 m	100/500 m	Polyester	White	Phenolic
PES90	210°C	90 gr/m ²	1.64 m	100 m	Polyester	White / Orange and green stripes	Polyester Phenolic & elastomere
PES90 MP	180°C	130 gr/m ²	1.50 m	50 m	Polyester + MP film	White / Orange and green stripes	Phenolic
PES105	210°C	105 gr/m ²	1.60 m	100/500 m	Polyester	White	Developed shape
DIATEX 1500 EV6	200°C	99 gr/m ²	1.74 m	100 m	Polyester	White	Structural bonding
DIATEX 1500 EV6 MP	180°C	136 gr/m ²	1.50 m	50 m	Polyester + MP film	White	Structural bonding
DIATEX 2000 EV6	200°C	139 gr/m ²	1.80 m	100 m	Polyester	White	Structural bonding

Customized peel ply available under request

More details ► www.diatex.com



Bagging films

PA205 HF is a carved bagging film for the vacuum moulding of composite parts. Its 3D structure provides a perfect vacuum drainage and allows to take out the bleeder for compaction or vacuum moulding combined to our MP Microporous peel ply. PA205 HF is a green bagging film as it enables use less peripheral device.

The new nylon bagging film **PO180** reduces waste. Used for vacuum moulding. It is available in lay-flat tubing and sheet, in 50 µ or 75 µ.

PO180 is suitable with polyester and epoxy resins, its composition based on polyamide and polypropylene provides good mechanical and chemical properties.



PA205 HF

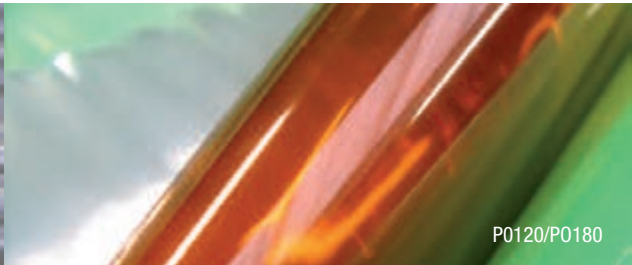

PO120/PO180

Product	Max. temp.	Thickness	Width	Length or surface	Vacuum elongation	Auto-release	Use with resin*
PO120	120°C	75 µ	2 / 4 / 6 / 8 / 10 m	+/- 800 m ²	400 %	Yes	E, P, VE, PH, EL
PO120	120°C	80 µ	12 & 16 m	25 / 30 / 53 m	400 %	Yes	E, P, VE, PH, EL
DIABAG 80	135°C	80 µ	1.7 / 3.4 m	100 m	750 %	No	E, PH, EL
PO150 XD2	145°C	80 µ	1.75 / 3.5 m	100 m	1000 %	Yes	E, PH, EL
PO150YJ	150°C	65 µ	1.5 / 2.8 / 4.57 m	170 / 216 m	400 %	Yes	E, P, VE, PH
PO160 TUBE	160°C	70 µ	86 / 100 / 125 / 150 200 / 300 / 350 / 400 mm	200 m	350 %	Yes	E, PH
PO175	177°C	50 to 75 µ	1.5 to 12 m	75 to 400 m	365 %	Yes	E, P, VE, EL
DIABAG 80 HT2	180°C	80 µ	1.5 / 3 m	100 m	650 %	No	E, PH, EL
PO180	180°C	50 & 75 µ	3 / 4 / 5 / 6 m	+/- 800 m ²	360 %	Yes	E, P, VE, EL
PO180 TUBE	180°C	50 & 75 µ	0.31 / 0.60 / 0.80 / 1.2 m	200 m	360 %	Yes	E, P, VE, EL
CAPRAN518	204°C	50 µ	2.54 / 3.15 / 4.06 m	152 / 305 m	415 %	Yes	E, P, VE, EL
CAPRAN518 TUBE	204°C	50 µ	1.52 m	305 m	415 %	Yes	E, P, VE, EL
PA205	205°C	50 & 75 µ	0.8 to 4.57 m	250 m	Poor	Yes	E, P, VE, EL
PA205 HF	205°C	75 µ	1.60 m	125 m	Poor	Yes	E, P, VE, EL, TP
PA232	232°C	50 & 75 µ	1.55 to 3.1 m	250 m	Poor	Yes	E, P, VE, EL
PTFE260	260°C	50 & 75 µ	1.22 m	82 m	Poor	Yes	E, P, VE, PH, EL
POLYIMIDE	400°C	25, 50, 75 µ	1.57 m	166 / 57 m	Poor	No	E, TP
POLYIMIDE HM	400°C	25 or 50µ	1.5 m	100 m	No	No	

* Resin code : E = epoxy - P = polyester - VE = vinyl ester - PH = phenolic - EL = elastomer - TP = thermoplastic.
PO150 XD, Diabag 80 & Diabag HT2 maximum pressure capability : 4 bars/57 PSI.

Perforated release films

Low temperature applications

Belonging to the polyolefin family, these films have a good chemical and thermal resistance providing an economic solution...

High temperature applications

Belonging to the fluoropolymer family, these perforated films have a very good chemical and thermal resistance.

Release with all resin systems, they are suitable for autoclave process.

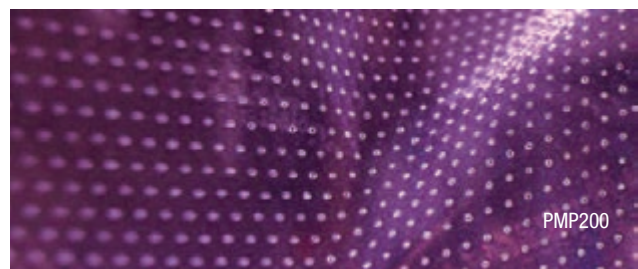

PMP200

Product	Max. temp.	Thickness	Width	Length	Elongation	Colour	Perforation	Type
ELA 20	125°C	25 µ	1 / 1.45 m	200 / 400 m	300 %	Blue	P1/P3/N	HDPE
PP40	160°C	40 µ	1.60 m	200 m	700 %	Red	P1/P3/N	PP
PMP200	200°C	30 µ	1.50 m	200 m	330 %	Purple	P1/P3/N	PMP
ETFE 230	230°C	13, 20 µ	1.30 / 1.53 m	150 / 153 m	300 %	Blue	P1/P3/N	ETFE
A 5000	260°C	25, 50 µ	1.22 m	183 m	300 %	Red	P1/P3/N	FEP
PTFE 260	260°C	25, 50 µ	1.22 m	154 / 77 m	550 %	Brown	P3/N	PTFE

N = non perforated - P1 = perforated P1 (large) - P3 = : perforated P3 (small).

Bleeders and breathers (non woven)

Non woven breather and bleeder felts made of polyester fibers. These are recommended for the moulding of elaborate forms. These bleeders are recommended for the vacuum technology with prepregs in autoclave. PES340 FR (Fire Retardant) is a bleeder/breather for high pressure and temperature cures. This non woven bleeder is made of polyester fibre which has undergone a special treatment against fire. It allows to limit the risk of fire during autoclave process.



PES 200

Product	Max. temp.	Weight	Width	Length	Elongation	Pressure	Type	Fire retardant
PES 150	205°C	150 gr/m ²	1.55 m	100 m	Very good	3 bars	Polyester	No
PES 200	205°C	200 gr/m ²	1.55 m	100 m	Very good	4 bars	Polyester	No
PES 340	205°C	340 gr/m ²	1.55 m	50/100 m	Good	7 bars	Polyester	No
PES 440 HDTEX	205°C	440 gr/m ²	1.55 m	50 m	Good	9 Bars	Polyester HDTEX	No
PES 150 FR	205°C	150 gr/m ²	1.55 m	100 m	Very good	3 bars	polyester	Yes
PES 340 FR	205°C	340 gr/m ²	1.55 m	50 m	Good	7 bars	polyester	Yes

Other width available under request

Glass tapes (woven)

This product is a woven glass bleeder and breather fabric recommended for high pressure and temperature cures. It provides an air channel and allows venting throughout the cure cycle to avoid porosity in the laminate. Due to its specific construction, this fiberglass tape offers a good flexibility and avoid risk of perforation of the bagging film.



RVE 136/220/050

Product	Max. temp.	Weight	Width	Length	Elongation	Pressure	Weave
RVE 136/220/050	700°C	220 gr/m ²	50 mm	100 m	No	15 bars	Taffeta
RVE 136/220/100	700°C	220 gr/m ²	100 mm	100 m	No	15 bars	Taffeta
RVE 136/220/150	700°C	220 gr/m ²	150 mm	100 m	No	15 bars	Taffeta
RVE 136/220/300	700°C	220 gr/m ²	300 mm	100 m	No	15 bars	Taffeta

Other width available under request

PTFE and silicone release interfaces

Porous or non porous PTFE coated glass fabrics, adhesive (silicone et acrylic) or non adhesive, bands or full width special PTFE products (seal, bands, treatment...).

The non porous adhesive version is used as a release sheet for permanent removal of the components.

The porous version is used as a release peel ply, and the screen version as a bleeder (autoclave application)

The 2 sides silicone coated paper 92 gr/m² PS2F85 is economic and ecofriendly. It can replace the PTFE coated glass fabrics and avoids using release agents.

This glossy release interface is easy to use thanks to its stiffness (no folds). It is suitable with all kind of resin.

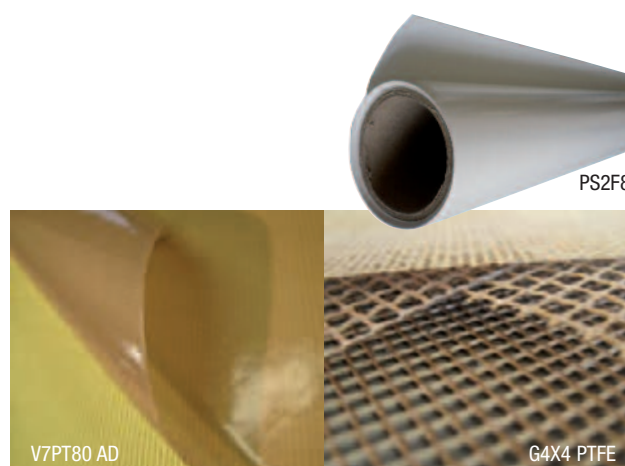

PS2F85

V7PT80 AD

G4X4 PTFE

Product	Max. temp.	Width	Length	Weight	Porosity	Thickness	Carrier type	Coating	Finish	Adhesive option
V7PT80	260°C	1/1.53 m	30/50 m	140 gr/m ²	Non Porous	80 µ	Glass	PTFE	Standard	Yes
V7PT125	260°C	1 m	30 m	250 gr/m ²	Non Porous	125 µ	Glass	PTFE	Glazed	Yes
V7PT140	260°C	1 m	30 m	290 gr/m ²	Non Porous	140 µ	Glass	PTFE	Glazed	Yes
V7PT250	260°C	1/1.53 m	30 m	490 gr/m ²	Non Porous	250 µ	Glass	PTFE	Glazed	Yes
V4PT76.3	260°C	1/1.53 m	30 m	65 gr/m ²	20-40	60 µ	Glass	PTFE	Fabric	No
G1X1 PTFE	260°C	1/1.53 m	30 m	520 gr/m ²	Stitch 1 x 1mm	685 µ	Glass	PTFE	Scrim	No
G4X4 PTFE	260°C	1 m	50 m	345 gr/m ²	Stitch 4 x 4mm	580 µ	Glass	PTFE	Scrim	No
PS1F75	240°C	1.6 m	200 m	90 gr/m ²	Non Porous	75 µ	Paper	Siliconized 1 side	Glazed	No
PS2F85	240°C	1.6 m	200m	92 gr/m ²	Non Porous	78 µ	Paper	Siliconized 2 sides	Glazed	No

Thermoshrinkable fabrics and films

Thermoshrinkable peel plies and thermoshrinkable films bands or full width. Use to compact and hot drying of the laminate.



Product	Max. temp.	Width	Length	Shrinkage at 150°C	Shrinkage at 200 °C	Beginning of shrinkage	Characteristic	Weight
DIATEX 1500	200°C	2,5 to 195 cm	100 m	10 %	16 %	100°C	PES 160 µ fabric	85 gr/m ²
DIATEX 2000	200°C	2,5 to 195 cm	100 m	11 %	15 %	100°C	PES 280 µ fabric	125 gr/m ²
Filament 160	160°C	2.5/5/7.5/10 cm	1000 m	15 %	15 %	80°C	PP 40 µ film	36 gr/m ²

Sealant tapes

Preformed sealants for the production of flexible seals. Sealant tapes are used to form a seal between the vacuum bagging film and the mould tool surface. Easy to implement, they don't dirty the tools. Compatible with most vacuum films and resins.

Very good chemical resistance. Contact us for sealant tapes to be used up to 400°C.



Product	Temp.	Dimensions	Roll	Colour	Use
LSM6000	90°C	0.3 cm x 1.3 cm x 13 m	22	Brown	Low temperature
LSM6013	90°C	12 mm x 3 mm x 10 m	22	Brown / Black	Debulking, double tack
LSM3000Flex	90°C	50 mm x 1.5 mm x 10 m	8	Grey	DIADRAIN MP sealing
LSM1310	110°C	0.25 cm x 1.2 cm x 15 m	22	Black	Medium temperature, hyper tack
LSM5200	140°C	12 mm x 2.5 mm x 15 m	10	Black	High tack
SM5127	205°C	0.32 cm x 1.27 cm x 7.62 m	40	Black	Standard
LSM7000	210°C	0.3 cm x 1.2 cm x 12.50 m	22	Yellow	High temperature, soft
SM5126	232°C	0.32 cm x 1.27 cm x 9.15 m	32	Black	High temperature
SM5160	371°C	0.32 cm x 1.27 cm x 9.15 m	24	Brown	Thermoplastic

Flash tapes

Joining, masking or protection tapes. Good mechanical and chemical resistance.



Product	Max. temp.	Width	Length	Adhesive support	Colour	Remark
K0107	180°C	25 mm	66 m	Polyester/Acrylic	Yellow	Standard use
K7666	204°C	13 / 25 / 50 mm	66 m	Polyester/Silicone	Blue	Standard use
PTFE-2	260°C	25 / 4 / 51 mm	33 m	PTFE/Silicone	Gray	High deformability
K7338	300°C	25 mm	33 m	Polyimide/Silicone	Orange	High temperature
K6337	300°C	25 / 50 / 100 mm	33 m	Polyimide/Acrylic	Orange	High temperature

Accessories and pipes

Discover all items on :

 www.diatex.com





2. Vacuum infusion & Infujection

DIATEX has designed a range of bagging materials for vacuum infusion, a transformation process which is often employed in boat industry and wind turbine sector. Positioned at the forefront of technology, DIATEX is constantly developing new solutions for increasing the productivity of market operators. The INFUPLEX product is the perfect answer as it consists of a bleeder and a separated film. Diatex provides a whole range of ecological products and the vacuum equipment required for the infusion process in compliance with our quality system (EN 9100 v 2009 - ISO 9001 v 2008 - Bureau Véritas).



Bagging materials

Optimized system by DIATEX

DIATEX provides technical support to select bagging materials in order to optimize the infusion process.



More details www.diatex.com

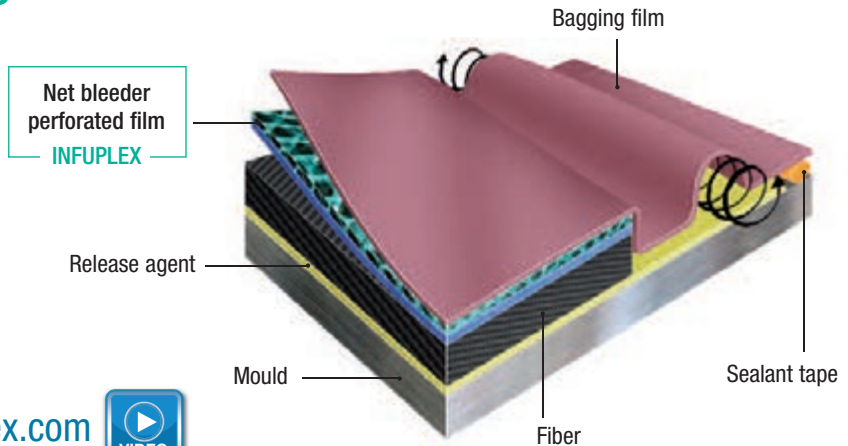

INFUPLEX

INFUPLEX is an innovative product created by DIATEX in 2007 which marks the evolution of the lamination process by infusion.

The infusion process involves the successive implementation of bagging materials such as :

- Peel ply
- Perforated release film
- Net bleeder

The standard procedure makes this implementation time consuming, difficult and has many draw-backs :

- Overlapping issue
- Over-use of spray adhesive
- Many cuts and successive operations : loss in productivity

INFUPLEX combines 2 of the 3 layers mentioned above in one product : perforated film and net bleeder. To be positioned directly on the part or on the peel ply, INFUPLEX removes the risk of forgetting the perforated film, of overlapping issues and ensures ease of use.

Benefits:

- Less waste
- Available in ISONET, OM70 and DIANET versions : different flow speeds
- Impregnation without defect
- Porosity of the additional layers unchanged/stable
- No risk of omissions
- No risk of dry areas due to overlaps
- Easy to use
- Reduces use of spray adhesive
- Increases the productivity
- Possibility of INFUPLEX high temperature 200°C

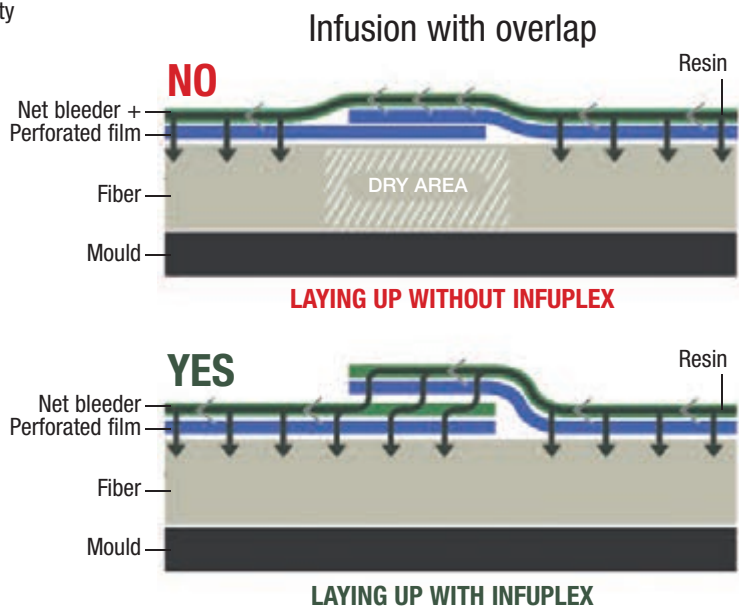
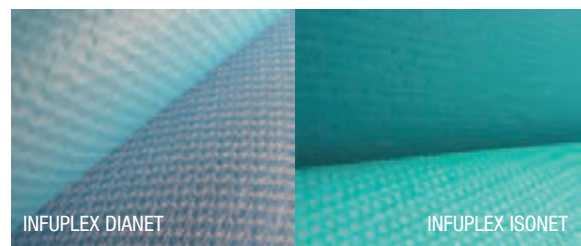

Product	Net bleeder	Perforated film	Resin flow speed	Use with resin
INFUPLEX ISONET	ISONET - 115 gr/m ²	ELA20 P1	Average	E,VE Polyester
INFUPLEX OM70	OM70 - 185 gr/m ²	ELA20 P1	Speed	E,VE Polyester
INFUPLEX DIANET135	DIANET135 - 135 gr/m ²	ELA20 P1	High speed	E,VE Polyester
INFUPLEX FLONET	FLONET - 112 gr/m ²	ELA20 P0	Very high speed	E,VE Polyester
INFUPLEX OM 70 PA	OM70 PA - 220 gr/m ²	PMP200 P1	Speed	Epoxy HT
INFUPLEX DIANET PA	DIANET PA - 125 gr/m ²	ETFE P1	High speed	Epoxy HT

E : epoxy VE : vinylster

Bagging films

PO120 and PO180 are new generation extra large extruded advanced copolymer films. They offer exceptional conformable characteristics, particularly when applied to awkward shapes with deep recesses or undercuts.

They allow the moulding of complex forms. They have release properties and can be used in direct contact with the resin.

PO120 can be offered up to 16 m width unwelded. Styrene resistant and non porous films can be used for both vacuum moulding or vacuum infusion technologies with epoxy or polyester.

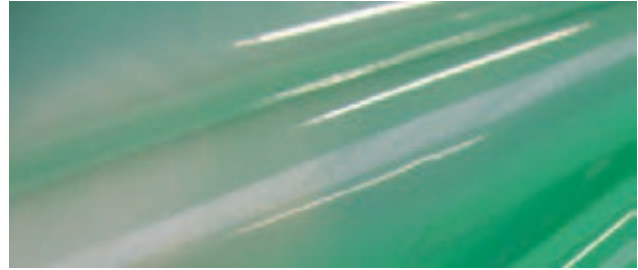

Product	Max. temp.	Thickness	Width	Length or surface	Vacuum elongation	Auto-release	Use with resin*
PO120	120°C	80 µ	12 / 16 m	25 / 30 / 53 m	400 %	Yes	E, P, VE, PH, EL
PO120	120°C	75 µ	2 / 4 / 6 / 8 / 10 m	+/- 800 m ²	400 %	Yes	E, P, VE, PH, EL
PO150YJ	150°C	65 µ	1.5 / 2.8 / 4.57 m	170 / 216 m	400 %	Yes	E, P, VE, PH
PO160 TUBE	160°C	70 µ	86 / 100 / 110 / 125 / 150 200 / 300 / 350 / 400 mm	200 m	350 %	Yes	E, PH
PO175	177°C	50 to 75 µ	1.5 to 12 m	75 to 400 m	365 %	Yes	E, P, VE, EL
PO180	180°C	50 to 75 µ	3 / 4 / 5 / 6 m	+/- 800 m ²	360 %	Yes	E, P, VE, PH, EL
PO180 TUBE	180°C	50 to 75 µ	0.31 / 0.60 / 0.80 / 1.2 m	200 m	360%	Yes	E, P, VE, PH, EL
CAPRAN 518	204°C	50 µ	2.54 / 3.15 / 4.06 m	152 / 305 m	415 %	Yes	E, P, VE, EL
CAPRAN 518 TUBE	204°C	50 µ	1.52 m	305 m	415 %	Yes	E, P, VE, EL
PA205	205°C	50 to 75 µ	0.8 to 4.57 m	250 m	Poor	Yes	E, P, VE, EL
PA232	232°C	50 to 75 µ	1.55 to 3.1 m	250 m	Poor	Yes	E, P, VE, EL

Resin code : E = epoxy - P = polyester - VE = vinyl ester - PH = phenolic - EL = elastomer - TP = thermoplastic.

Perforated films

The high density perforation is controlled by special equipment that guarantee a quality of perforation made by hot needles throughout the manufacturing process.



PP40 PERFORATED P1

Product	Max. temp.	Thickness	Width	Length	Elongation	Colour	Perforation	Type
ELA20	125°C	25 µ	1 & 1.45 m	400 m	300 %	Blue	P1	HDPE
PP40	160°C	40 µ	1.60 m	200 m	700%	Red	P1	PP
PMP200	200°C	30 µ	1.50 m	200 m	330%	Red	P1	PMP
ETFE230	230°C	20 µ	1.50 m	150 m	300%	Blue	P1	ETFE

N = non perforated - P1 = perforated P1 (large) - P3 = : perforated P3 (small).

Net bleeders for infusion

DIATEX proposes knitted net bleeders made of polyethylene yarns. Several constructions are available providing different flow resin speeds. In order to meet a rising demand for high temperature vacuum infusion solutions, Diatex has developed a specific range of net bleeder withstanding temperature up to 200°C. Based on

polyamide, these net bleeders have been heat set in order to avoid the rolling up of the flanges.

These products do not contain oil, silicon or any other pollutants from production process. They enable a high productivity for large parts.

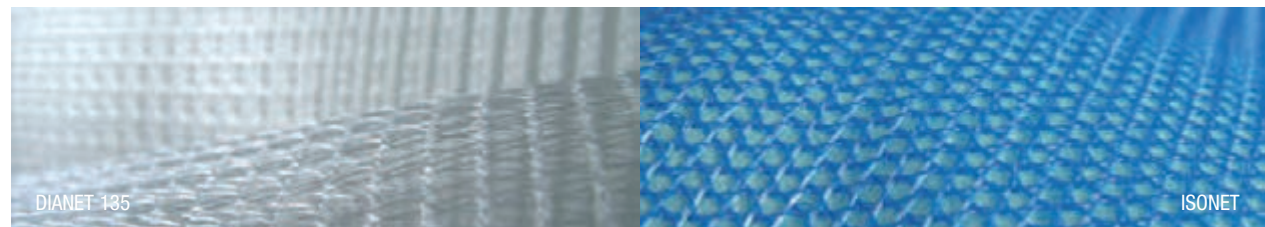

Product	Max. temp.	Thickness	Width	Length	Weight	Colour	Type	Resin flow speed
ISONET	90°C	900 µ	2 / 4 m	100 / 50 ml	115 gr/m ²	Blue	CO PE	Average
OM 70	90°C	1117 µ	2 / 4 m	100 / 50 ml	180 gr/m ²	Black/green	PE	Speed
DRAIKO	90°C	1066 µ	2 / 4 m	100 / 50 ml	105 gr/m ²	Black	PE	High speed
DIANET 135	90°C	1190 µ	2 / 4 m	100 ml	135 gr/m ²	Green	CO PE	High speed
FLONET	90°C	1100 µ	2 / 4 m	100 / 50 ml	112 gr/m ²	Yellow	CO PE	Very high speed
DIANET PA	200°C	1050 µ	2 m	100 ml	125 gr/m ²	White	PA	High speed
OM 70 PA	200°C	1100 µ	1.45 m	100 ml	220 gr/m ²	White	PA	Speed

Peel ply

Complete range of peel plies : from 64 to 185 gr/m², dyed, white or undyed with stripes, polyamide or polyester, bands or full Width PA85 is the standard quality, taffetas weave, 85 gr/m², white with stripes. Those fabrics are used to impart a textured surface to the moulded component to improve adhesion in secondary bonding or painting. We are able to manufacture your own peel ply with specific characteristics.

All our peel plies are treated in order to remove all pollutant

products (like silicones for example) which could be found on the laminate. We control the porosity of our peel plies in order to guarantee the repetitiveness of the infusion process.

PA80AD is an adhesive version with only 8gr/m² of glue. Spray is not recommended for the vacuum infusion, because you can't apply it uniformly. Furthermore a large part of the solvent goes in the workshop atmosphere : the vacuum philosophy is to avoid COV emission.

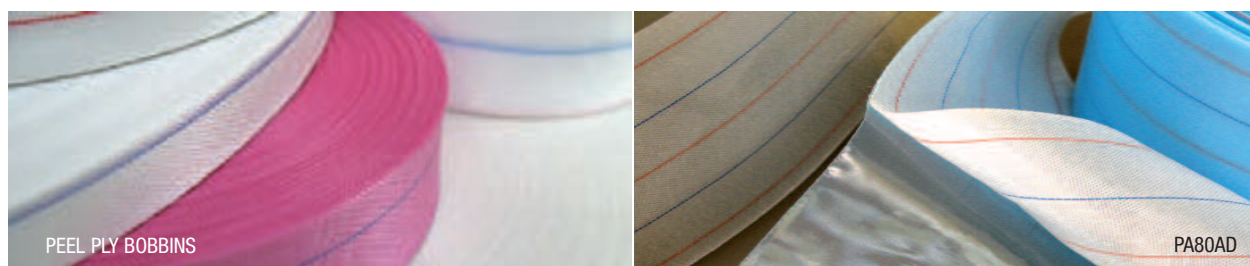

Product	Max. temp.	Weight	Width	Length	Weave	Type	Colour	Use
PA64	190°C	64 gr/m ²	1.57 m	100 m	Taffetas	Polyamide	White/ red stripes	Thin surface
PA80	185°C	80 gr/m ²	1.56 m	100 m	Taffetas	Polyamide	White / Red & blue stripes	Economic
PA80AD	185°C	80 gr/m ²	1.56 m	100 m	Taffetas	Polyamide	White / Red & blue stripes + Adhesive	Economic + Adhesive
PA80 FLUO	185°C	83 gr/m ²	1.63 m	100 m	Taffetas	Polyamide	Yellow / Red & blue stripes	Carbon
PA85	185°C	85 gr/m ²	1.60 m	100 / 500 m	Taffetas	Polyamide	White / Blue stripes	Standard
PA90	185°C	90 gr/m ²	1.56 m	100 / 500 m	Taffetas	Polyamide	Pink / Blue stripes	Carbon
PA91	200°C	91 gr/m ²	1.60 m	100 m	Taffetas	Polyamide	White/red stripes	Hand lay up, infusion
PA95	185°C	104 gr/m ²	1.56 m	100 / 500 m	Taffetas	Polyamide	White / Blue stripes	Carbon
PA95 ST	185°C	104 gr/m ²	1.56 m	100 / 500 m	Taffetas	Polyamide	White	Carbon
PA100	185°C	107 gr/m ²	1.56 m	100 / 500 m	Taffetas	Polyamide	Pink / Blue stripes	Carbon
PA100 ST	185°C	107 gr/m ²	1.56 m	100 / 500 m	Taffetas	Polyamide	Pink	Carbon
PA105	185°C	105 gr/m ²	1.47 m	100 m	Twill 2.2	Polyamide	White / Blue stripes	Developed shape
PES85	210°C	85 gr/m ²	1.64 m	100 / 500 m	Taffetas	Polyester	White	Phenolic
PES90	210°C	90 gr/m ²	1.64 m	100 m	Taffetas	Polyester	White / orange and green stripes	Phenolic
PES105	210°C	105 gr/m ²	1.60 m	100 / 500 m	Twill 2.2	Polyester	White	Developed shape
DIATEX 1500EV6	200°C	99 gr/m ²	1.74 m	100 m	Taffetas	Polyester	White	Structural bonding
DIATEX 2000EV6	200°C	139 gr/m ²	1.80 m	100 m	Taffetas	Polyester	White	Structural bonding

Customized peel ply available under request

PTFE and silicone release interfaces

Porous or non porous PTFE coated glass fabrics, adhesive (silicone et acrylic) or non adhesive, bands or full width special PTFE products (seal, bands, treatment...).

Non porous adhesive version is used as a release sheet for permanent removal of the components.

Porous version is used as a release peel ply, and screen version as a bleeder (autoclave application).

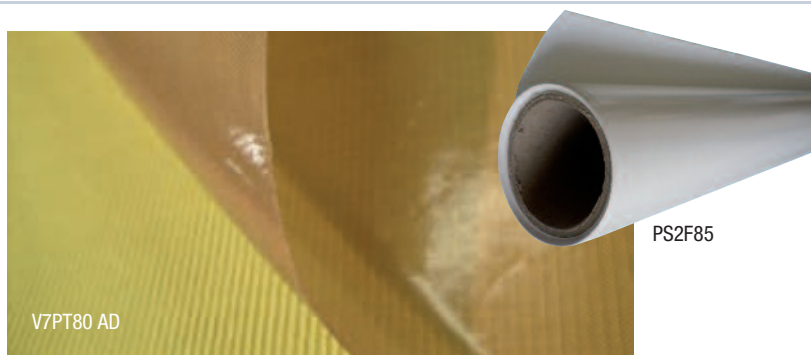

Product	Max. temp.	Width	Length	Weight	Porosity	Thickness	Carrier type	Coating	Finish	Adhesive option
V7PT80	260°C	1 / 1.53 m	30/50 m	140 gr/m ²	Non Porous	80 µ	Glass	PTFE	Standard	Yes
V7PT125	260°C	1 m	30 m	250 gr/m ²	Non Porous	125 µ	Glass	PTFE	Glazed	Yes
V7PT140	260°C	1 m	30 m	290 gr/m ²	Non Porous	140 µ	Glass	PTFE	Glazed	Yes
V7PT250	260°C	1 / 1.53 m	30 m	490 gr/m ²	Non Porous	250 µ	Glass	PTFE	Glazed	Yes
V4PT76.3	260°C	1 / 1.53 m	30 m	65 gr/m ²	20-40	60 µ	Glass	PTFE	Fabric	No
G1X1 PTFE	260°C	1 / 1.53 m	30 m	520 gr/m ²	Stitch 1 x 1mm	685 µ	Glass	PTFE	Scrim	No
G4X4 PTFE	260°C	1 m	50 m	345 gr/m ²	Stitch 4 x 4mm	580 µ	Glass	PTFE	Scrim	No
PS1F75	240°C	1.6 m	200 m	90 gr/m ²	Non Porous	75 µ	Paper	Siliconized 1 side	Glazed	No
PS2F85	240°C	1.6 m	200m	92 gr/m ²	Non Porous	78 µ	Paper	Siliconized 2 sides	Glazed	No

Sealant tapes

Preformed sealants for the production of flexible seals. Sealant tapes are used to form a seal between the vacuum bagging film and the mould tool surface. Easy to implement, they don't dirty the tools. Compatible with most vacuum films and resins. Very good chemical resistance. Contact us for sealant tapes to be used up to 400°C.

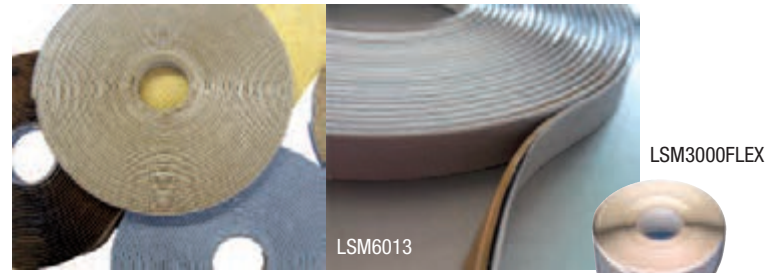

Product	Temp. max	Dimensions	Roll	Colour	Use
LSM6000	90°C	0.3 cm x 1.3 cm x 13 m	22	Brown	Low temperature
LSM6013	90°C	12 mm x 3 mm x 10 m	22	Brown / Black	Debulking, double tack
LSM3000 Flex	90°C	50 mm x 1.5 mm x 10 m	8	Grey	DIADRAIN MP sealing
LSM1310	110°C	0.25 cm x 1.2 cm x 15 m	22	Black	Medium temperature hyper tack
LSM5200	140°C	12 mm x 2.5 mm x 15m	10	Black	High tack
SM5127	205°C	0.32 cm x 1.27 cm x 7.62 m	40	Black	Standard
LSM7000	210°C	0.3 cm x 1.3 cm x 12,50 m	22	Yellow	High temperature, soft
SM5126	232°C	0.32 cm x 1.27 cm x 9.15 m	32	Black	High temperature
SM5160	371°C	0.32 cm x 1.27 cm x 9.15 m	24	Brown	Thermoplastic

Adhesive spray : INFUTAC

INFUTAC is made for the assembly of dry reinforcements and vacuum devices in vacuum infusion and RTM processes.

- Holding of hybrid materials
- Optimal adhesion during the molding
- Low drying shrinkage
- Exact application thanks to a ultrafine spraying and a green tracer
- High instantaneous adhesion

INFUTAC adhesive made for the vacuum infusion process, ensures a perfect adhesion of the reinforcements during the molding. The glue does not interfere on the surface quality and surface quality and structural integrity.



Box of 12 aerosols

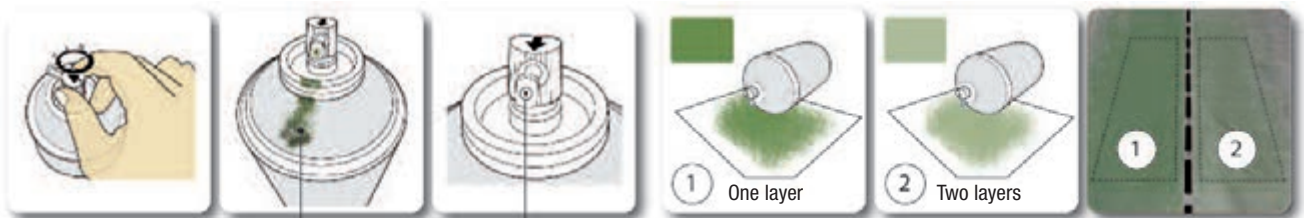

Flow control thanks to a regulation button L (low), M (medium), H (high).

Green tracer

Unblocked nozzle

All INFUTAC sprays are supplied with adjustable spray flow nozzle

Available Quantities

INFUTAC CLEAR (transparent) is available in spray of 500 ml
 INFUTAC GREEN (green color) is available in 2 volumes/spray (500/610 ml) and 3 volumes/canister (19/63/125 L)

PRODUCT	SPRAY	SPRAY	SPRAY	CANISTER	CANISTER	CANISTER
VOLUME	500 ml	610 ml	500 ml	19.1 L	63.5 L	131.5 L
CAN	Consumable	Consumable	Consumable	Consumable	Safety cans (recovery by DIATEX)	Safety cans (recovery by DIATEX)
NB/PALLET	1080	1080	1080	36	9	2

PRODUCT	INFUCLEAN	PIPE	GUN	VALVE
CHARACTERISTICS	4.7 L Consumable	3.66m / 5.5m Reusable	Delivered with nozzle 9501 Reusable	Compatible pipe Reusable

SPIRALNET

When using a spiral tube as a resin line in vacuum infusion process, one of the biggest issue is the marking of the laminate. In order to get rid of this problem, DIATEX developed a ready to use advanced solution : SPIRALNET.

This product combines a tube mesh together with a spiral tube in order to optimize the resin distribution and avoid the marking of the laminate during the infusion process.

SPIRALNET can be also used as vacuum line.

It can replace the mould flange when this one is too narrow.

Technical characteristics :

- No marking of the laminate
- Ready to use
- Standard supply : rolls of 100 lm
- Spiral tube 12 x 14 mm
- Infusion net OM70
- Can be used with all nets
- Max service temperature 90°C
- Assembly technology : welded

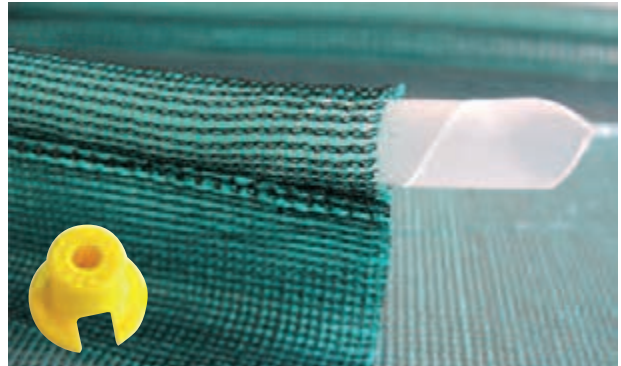

SPIRAL MP*

SPIRAL MP is a microporous vacuum channel used for vacuum infusion parts manufacturing.

SPIRAL MP is composed of a spiral tube wrapped in the PES90MP microporous peel ply.

SPIRAL MP is very flexible, easy to cut in customized sizes and enables a very fast and easy application of vacuum channels.

To reduce marking, use the MICROPOROUS DIADRAIN MP.

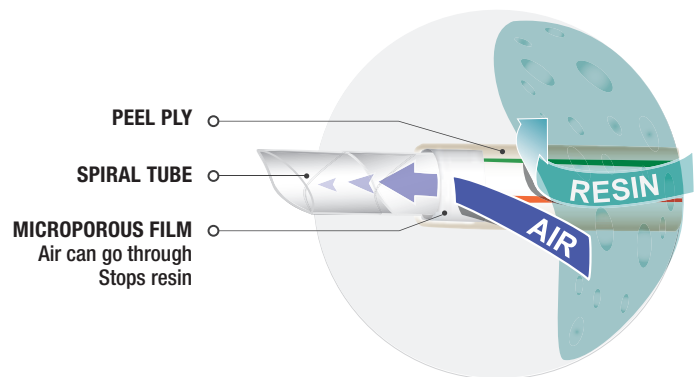

DIADRAIN MP*

The DIADRAIN microporous is a brand new vacuum line and resin barrier.

Advantages :

- Easy to apply
- Permanent vacuum line
- Reduces the risk of dry spots
- Improves the quality of your laminate

DIATEX commits into "Eco Design" in order to meet its customers requirements. The aim is to manufacture a range of bagging materials more environmentally friendly, in compliance with recommendations such as REACH and Oeko Tex.

In order to facilitate the implementation, Diatex has developed 2 new accessories

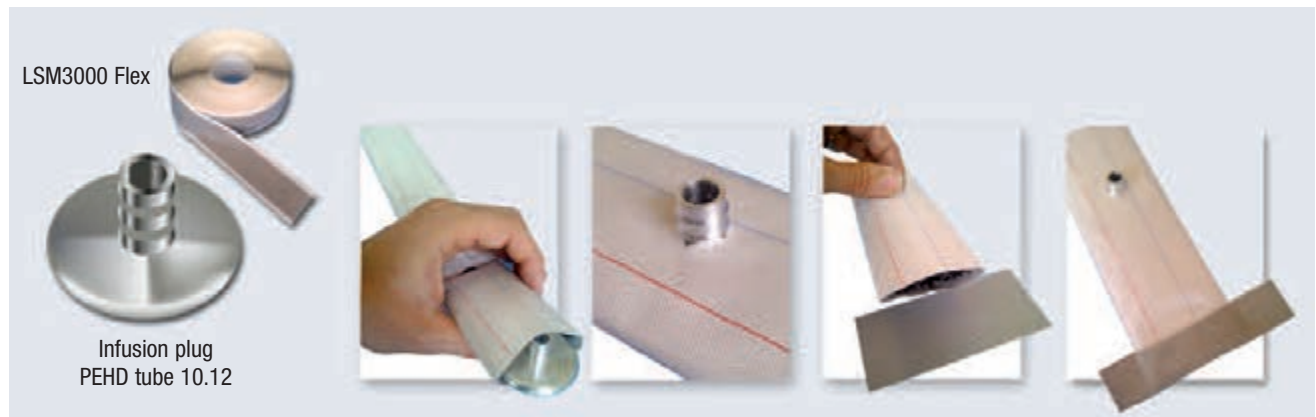
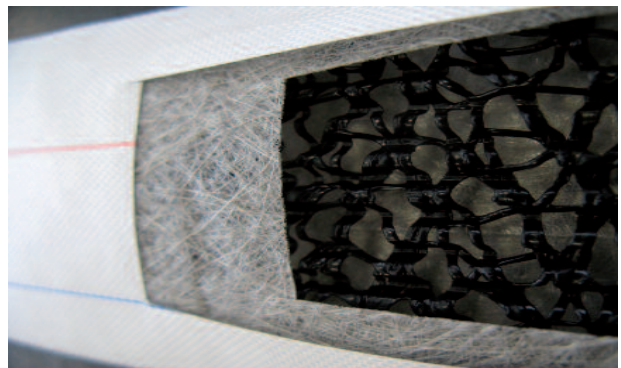

* Availability may be subject to authorization (please consult)

Adhesive glass screen tape

GLAS50AD is an adhesive glass screen made to set fibers, bagging materials and the core materials during vacuum infusion process or vacuum moulding processes. This double side adhesive screen can be used in direct contact with the fiber.

GLAS50AD doesn't modify the resin flow.

100% non hazardous, solvent free, this adhesive tape is the best solution to set safely the fibers. With GLAS50AD you know exactly the quantity of glue used per m², furthermore you can control this quantity which is not the case with spray.

GLAS50AD is made of non hazardous glue 100% soluble with resins. After infusion, the glass screen works like a reinforcement. GLAS50AD was made to replace hazardous aerosols or glue spray guns.



Product	Max. temp.	Thickness	Width	Length	Weight	Type	Weave
GLAS50AD	180°C	450 μ	50 mm	50 ml	135 gr/m ²	Glass + AD	Scrim
GLAS25AD	180°C	450 μ	25 mm	50 ml	135 gr/m ²	Glass + AD	Scrim

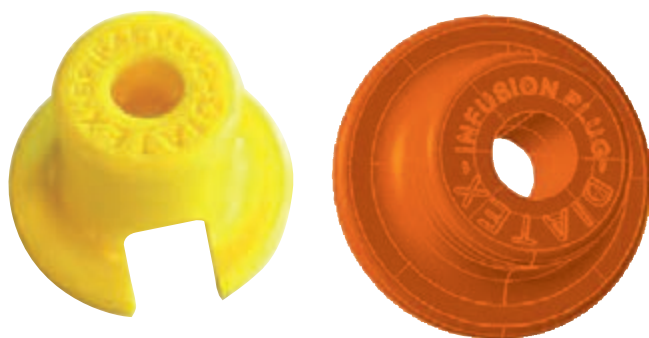

Connectors / plugs

To reduce leak risks and manufacturing costs, DIATEX has developed a new range of connectors: SPIRAL PLUG and INFUSION PLUG.

Accessories and tubes

Discover all items on :

▶ www.diatex.com

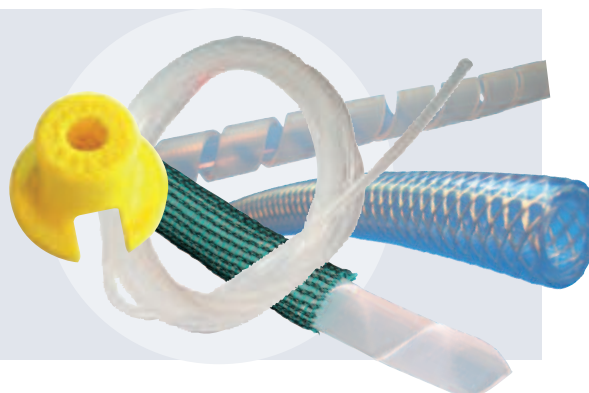

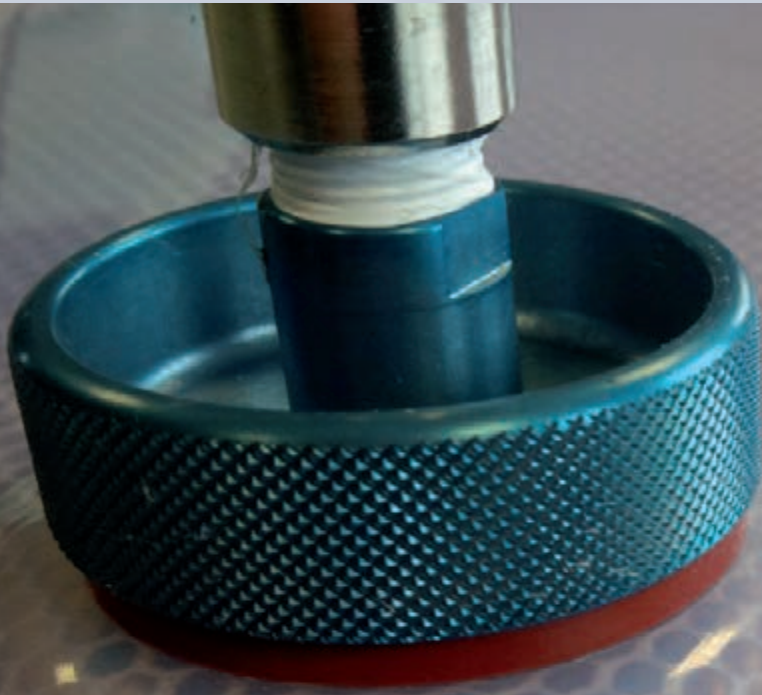

3. Reusable membranes

Diatex provides a complete range of reusable membranes for infusion, debulking and vacuum molding in ovens or autoclaves. This range is composed of RTV silicone spray, vulcanized or raw HTV silicone rolls and rubber.



Our range

Reference	Shore Hardness(A)	Vulcanized	Non Vulcanized	Type	Packaging	Thickness	Color
DIASIL 20	20		x	RTV Spray	25 Kg A + 25 Kg B		Purple
DIASIL 45	45	x	x	HTV	1.30 m x X ml	1.5 mm	Grey
DIASIL 50	50	x	x	HTV	1.40 m x X ml	1.5 mm	Blue
DIASIL 60	60	x		HTV	1.20 m x X ml	0.5 mm	Translucent
ELASTIBAG	40	x		Latex	1 m x X ml	0.55 mm	Yellow
PARABLOND	45	x		Rubber	1.40 m x X ml	1.0 mm	Brown

Diatex is able to manufacture silicone tools

- Silicone tools for infusion (DIASIL 20)
- Silicone zipped bags (DIASILBAG)
- Silicone tools on metal frame

DIASIL 45, 50 and 60 silicone and ELASTIBAG and PARABLOND are sold by rolls or LM

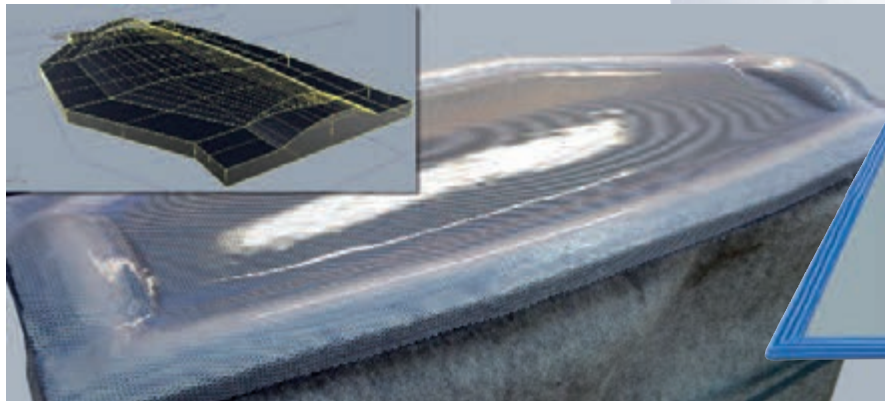

SILICONE DIASIL 20

SILICONE DIASILBAG COVER

Customized membranes

Diatex offers customized silicone membranes.

Used technologies

- Sprayable silicone DIASIL 20
 - Heat-vulcanizable silicone (into autoclaves)
- DIATEX expertise for the manufacturing of silicone membranes for Infusion or Vacuum moulding ensures you gain maximum
- Improved handling thanks to a thickness optimization
 - Modeling, calibration, manufacturing of technical flanges
 - Perfect sealing checked before dispatching (Drop-test quality control)

Send us your 3D tooling drawings for a quick study (< 48 hours). The high reactivity of our Silicone workshop will ensure a reduced preparation time.

DIASIL 50



DIASIL 20

Spraying equipments



SC2
2-component SYSTEM
 Mixing and spraying silicone
 equipment 1:1



SC3 and CS4
3-component system
 Mixing and spraying silicone 1:1, 1:10 and 1:25
 This equipment enables you to add,
 a non-thixotropic agent or an inhibitor
 for vertical wall spraying.

Silicone ancillaries

You will find in our silicone RTV ancillaries

- Spraying equipments : SC2 2, SC3 and SC4
- Sprayable silicone DIASIL 20
- Tooling ancillaries : various resin channels, high temperature inserts, silicone repair kits, injection fittings, calibrated wax, knitted reinforcement
- Equipment ancillaries : spray nozzles, static mixer, quick connector for spray nozzle

Discover all items on :
 www.diatex.com

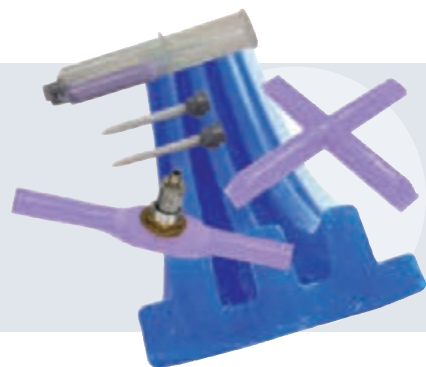

4. RTM & RTM Light

DIATEX has 18 years of experience in the field of RTM injection. DIATEX ensures also equipment maintenance and proposes a large range of RTM Light accessories and tools design. The RTM CIJECT range of machines combines technology and innovation in addition to a proven and innovative design : Composite Integration Ltd proposes the safest and most ergonomic machines on the market. During the past five years, Composite Integration Ltd has extended its range of products as well as its offer : machines, fittings, tools design... The co-directors of Composite Integration Ltd have worked in close collaboration with DIATEX since 1992 and have chosen this company to exclusively represent their range on the French market and to ensure equipment maintenance.

Valve V400

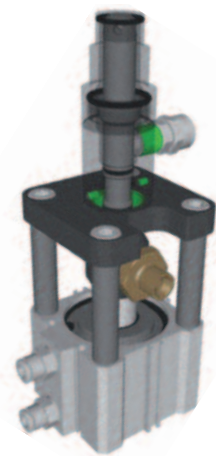

The Injection valve links the resin injection/meter mix machine to the inlet port of a typical closed mould. It ensures clean operation, straightforward isolation of the mould cavity, vacuum tight sealing and is easily cleaned as part of the normal machine cycle.

In addition, the use of such a valve enables automation of the process and reduces the need for operator intervention.

Infusion versions and/or high temperature are also available.

In mould air ejector

The valve is designed to provide maximum air-flow with the minimum of interference with mould surface. The 17 mm flush end surface is considerably smaller than most other currently available units. The high opening force created by the larger integral piston at the rear of the valve ensures reliable and powerful operation. The valve is machined from steel and is treated to provide a hardened and corrosion resistant surface. The valve terminates in a standard metric thread and so can be threaded into the mould structure and is easily removable. A threaded metal insert is included for bonding into composite moulds. The closing force is provided by an internal spring but air pressure can be applied if working against high in-mould pressures. Both air connections are positioned in the end-cap surface enable easy access once installed. The valve is operated remotely by a pneumatic push-button switch connected via 6 mm pipes and fittings (Part N°XE-0021). A single push-button may be used to operate multiple ejectors.



Overlay

This overlay is a non woven fabric. It improves the aspect of laminates when applied on direct contact with the mould or on a gel coat.

This non woven overlay has a high porosity and elongation which improves good air and resin flow.

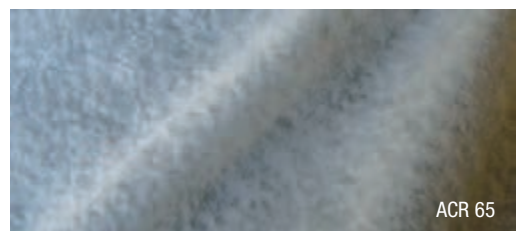

ACR 65

Product	Colour	Weight	Weave	Width	Length	Elongation
ACR 65	White	65 gr/m ²	non woven	From 1.50 to 3.5 m - Standard 1.5 m	200 ml	110 %

Accessories

Injectors : 3 options

10 mm	10 mm	Valve
XM-0404	XM-0305	XE-0015
+	+	+
	MM-0014	MM-1501

Vents : 3 options

0,5 L	2 L	8 L
XE-0400	XE-0211	XE-0500
	+	
	MM-0014	

Resin flow profile

RD20-4530

Location cone

MM-0020

Vacuum seals

	Calibration seals
RD476-003	
	RD20-3391
RD20-5895	

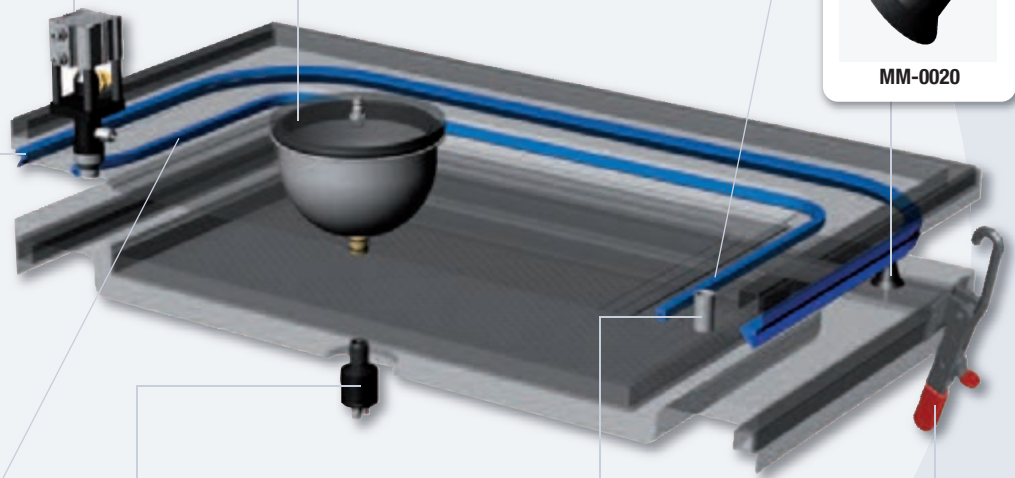

Resin seals : 2 options

Calibration seals	
RD-001-002	RD20-3340
Silicone seals	
RD420-0092	RD421-001

Air ejector

20 mm
MM-2001
+
XE-0020

Vacuum connexion

20 mm	10 mm
QAC94F	
+	+
QAC93	XM-0404

Clamps

SA-0351
or
SA-0331



5. Vacuum equipments

DIATEX provides all vacuum equipments. In addition to developing a specific range of products for the industry of composite materials in close collaboration with its MIL'S partner, DIATEX also offers a complete range of pumps with lubricated paddles and vacuum plants with different vacuum levels adapted to vacuum applications. Diatex also proposes measuring devices for monitoring pressure, temperature and leakage.





PS Range

- Dedicated to small composite parts
- Oil less
- Very economical
- Compact and independant vacuum plant
- Noiseless
- Range from 3 to 10 m³/h



Product	Nominal capacity/pump L.min ⁻¹ 50 Hz	End vacuum mbar	Power pump W	Speed ter.min ⁻¹ 50 Hz	Weight Kg
PS 2V	47	-900	200	1465	7
PS 5V	81	-900	170	1465	9
PS 7V	106	-900	250	1425	9
PS 12V	168	-900	360	1425	9
PS 5VH	58	-980	170	1465	9
PS 7VH	79	-980	250	1425	9
PS 12VH	123	-980	360	1425	9

Automatic vacuum pumps

The automatic vacuum pumps, are perfectly adapted for to composite industry :
vacuum moulding, vacuum infusion and RTM or RTM LIGHT.

- Lubricated rotary vanes vacuum pumps
- Standardization of spare parts for an easier maintenance
- Possibility to have a personalized covering plate
- Continuous running from atmospheric pressure to end vacuum
- Air cooling
- Standard motor coupling
- IP 55 Motor - F class



Product	Nominal capacity/pump (m3-h) 50 Hz	Power pump (kW) 50 Hz	End vacuum (mbar) HV	Weight (kg)
Rotomil's C8	8	0.25	3	10
Evisa E17.3	19.2	0.55	5.10 ⁻¹	36
Evisa E25.3	30	0.75	5.10 ⁻¹	39
Evisa E40.3	47,7	1.10	5.10 ⁻¹	52
Evisa E65.3*	64.3	1.50	1.5.10 ⁻¹	75
Evisa E100.3*	96	2.20	1.5.10 ⁻¹	85
Evisa E150.R	132	3.00	6.10 ⁻²	154
Evisa E200.R	198	4.00	6.10 ⁻²	140
Evisa E300.R	288	5.50	6.10 ⁻²	162

*ATEX version available for explosible atmospheres regarding to INERIS Certificate (standard temperature security).

Vacuum plants Indusvac

The vacuum tank allows a better optimisation of the vacuum level and an economy of the vacuum pump.

- Compact and independent vacuum plant
- Lubricated rotary vanes vacuum pump
- Regulation by mechanical vacuum switch
- Starting board and integrated hour meter
- Different available regulation modes

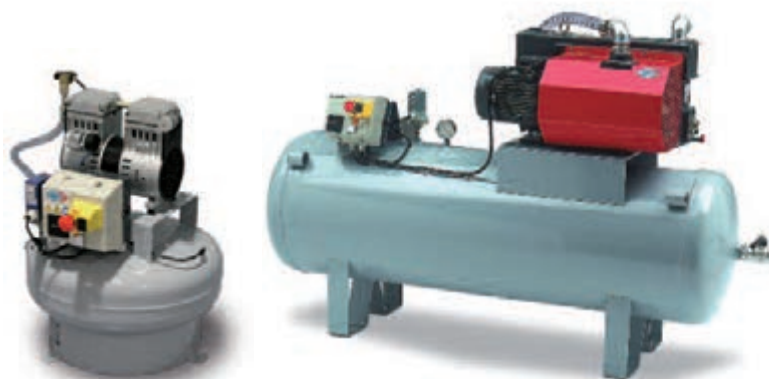

Product	Nominal capacity (m3-h) 50 Hz	Power pump (kW) 50 Hz	Receiver capacity (L)	Weight (kg)
Minivac 1 E25	30	0.75	70	85
Indusvac 1 E25	30	0.75	300	85
Indusvac 1 E40	47	1.10	300	110
Indusvac 1 E65*	65	1.50	300	145
Indusvac 1 E100*	96	2.20	300	210
Indusvac 1 E150	150	3.00	500	260
Indusvac 1 E200*	190	4.00	500	280
Indusvac 1 E300*	288	5.50	500	370

*ATEX version available for explosible atmospheres regarding to INERIS Certificate (standard temperature security).

Vacuum plants Compositvac

These vacuum plants delivered 2 different vacuum levels with only one vacuum pump :

- One vacuum for close the mould.
- One vacuum to assist the injection

The vacuum tank allows a better optimisation of the vacuum level and a economy of the vacuum pump. The 2 vacuum levels are adjustable in function of the resin systems used and the applications. The vacuum plants COMPOSITVAC are design to be used with the most RTM machines.

- Lubricated rotary vanes vacuum pump
- Mobile or static vacuum plant with 2 vacuum levels
- Running with vacuum switch for maxi vacuum and with vacuum operated solenoid valve for regulated vacuum
- Activated carbon filter for odors and aggressive vapour removal
- Several outlets for maxi and regulated vacuum



Product	Nominal capacity (m3-h) 50 Hz	Power pump (kW) 50 Hz	Receiver capacity (L)	Weight (kg)
Mobil Compositvac E25	30	0.75	70	120
Mobil Compositvac E40	47	1.10	250	245
Mobil Compositvac E65	65	1.50	250	265
Fix Compositvac E 65	65	1.50	500 + 80	260
Fix Compositvac E100	96	2.20	500 + 80	280

Vacuum regulator and vacuumeters

To regulate the vacuum between -0,95 Bar and air pressure.
Speed up to 240 L/min
Included vacuumeter and support



Ultrasonic leak detector, control of leaks location

As a gas or liquid passes through a small restrictive opening, ultrasonic noise is created. While this noise is imperceptible to the ear it is very easily located by the Leak Detector using the ultrasonic probe.

The ultrasound is indicated by LED-array and an audible tone through the earphone headset. As the instrument is moved closer to the ultrasonic source more LED's will light up. Simultaneously, the frequency of the tone rises.

The ultrasonic leak detector is particularly adapted to the control of the flexible airtightness during the vacuum processes like vacuum infusion, vacuum moulding and RTM or RTM LIGHT.

- Supply with a handbag



DETECT 10

DETECT 05

IMPS In Mould Pressure Sensor

A pressure monitoring system designed to use with vacuum or pressure composite injection or infusion processes. Ceramic sensor can be mounted in any position and resin can be cured directly against sensor face. Includes 10 m cable and connector for attachment to either a readout/control unit or a Ciject injection machine.

Control unit with twin LED display. Upper display shows current pressure reading in bar. Lower display is set by the operator in bar. If the set pressure is exceeded, an electro-pneumatic valve is actuated. Valve has N/O (normally open) and N/C (normally closed) ports.



CERAMIC SENSOR AND READOUT UNIT

Infrared thermometer gun

With this infrared thermometer gun, you just have to aim the laser guide at the target and shoot to acquire temperature readings of any surface in less than a second. A laser sighting beam enables precise aiming at the target surface, while a data-hold function freezes the display reading.

This infrared thermometer gun is a very convenient solution to check the resin temperature. The unit also features backlighting at the touch of a button, a low-battery indicator, automatic maximum recording, selectable °F/°C button.



The logo consists of a blue triangle pointing to the right, containing the text "DIA TEX" in white, bold, uppercase letters.

DIA TEX

Composite process materials



www.diatex.com

The logo features a circular emblem on the left containing a crown and a shield. To the right of the emblem, the text "EN 9100" and "ISO9001" are stacked vertically. Below this, the text "Oeko-Tex®" is written in a smaller font.

EN 9100
ISO9001
Oeko-Tex®

DIATEX

Composite process materials

Composite division

Vacuum moulding

Reusable membranes

Vacuum equipment



www.diatex.com

 EN 9100
ISO9001
Oeko-Tex®

DIATEX:

58, rue des Sources - ZI La Mouche - 69230 St Genis Laval - France
Tél. 33 (0) 478 86 85 00 - Fax. 33 (0) 478 51 26 38 - info@diatex.com